

# KSET9XE2

Product family	Hood
Hood Type	Integrated (semi) hood
Design	Telescopic
Extraction	Extraction
Material	Stainless steel
Type of steel	Brushed
EAN code	8017709279943
Hood width	90 cm



## Aesthetics

Aesthetic Colour	Universale Silver	Serigraphy colour Logo	Black Silk screen
------------------	-------------------	------------------------	-------------------

## Controls

Control setting	Slider
-----------------	--------

## Programme / Functions

No. of speeds	3
---------------	---

## Technical Features

			
No. of lights	2	No. of filters	2
Light type	LED	Anti-grease filters	Aluminium
Light Power	4 W	Vent outlet	120 mm
Light color temperature scale (°K)	3000 °K	Minimum distance from GAS hob	650 mm
Free outlet maximum capacity	520 m <sup>3</sup> /h	Minimum distance from ELECTRIC hob	450 mm
Motor power	230 W		

	Extraction rate IEC 61591 [m <sup>3</sup> /h]	Noise level IEC 60704-2-13 [dB(A)]
Speed 1	270	53
Speed 2	360	58
Speed 3	500	66

## Accessories Included

Tube reduction Yes

## Performance / Energy Label



Annual Efficiency Consumption (AEChood)	127 kWh/a	Airbourne acoustical A-weighted sound Power Emission at minimum speed (SPEmin)	53 dB(A)
Energy efficiency class (EEC)	D	Airborne acoustical A-weighted sound Power Emission at maximum speed (SPEmax)	66 dB(A)
Fluid Dynamic Efficiency (FDE)	9.8	Time increase factor (F)	1.6
Fluid Dynamic Efficiency class (FDEC)	E	Energy Efficiency Index	94.8
Lighting Efficiency (LE)	16 lux/W	Measured air flow rate at best efficiency point (Qbep)	306 m <sup>3</sup> /h
Lighting Efficiency Class (LEC)	D	Measured air pressure at best efficiency point (Pbep)	238 Pa
Grease Filtering Efficiency (GFE)	75.1 %	Measured electric power input at best efficiency point (Wbep)	207 W
Grease Filtering Efficiency Class (GFEC)	C	Nominal Power consumption of the light system (WL)	8 W
Air flow at minumum speed (Qmin)	270 m <sup>3</sup> /h	Average illumination of the light on the cooking surface (Emiddle)	130 lux
Air flow at maximum speed (Qmax)	500 m <sup>3</sup> /h	Sound power level at highest setting (Lwa)	66 dB(A)

## Electrical Connection

Electrical connection rating	238 W	Frequency (Hz)	50 Hz
Voltage	220-240 V	Power supply cable length	1500 mm

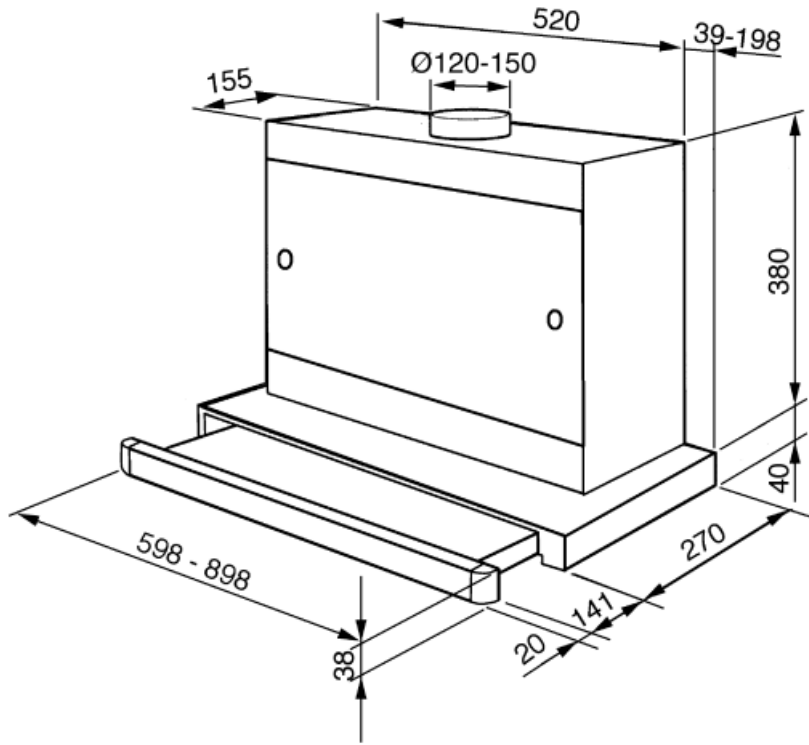

---

## Not included accessories

---

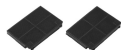

KITFC156

Charcoal filters Kit 2 pieces

---

## Symbols glossary (TT)

---



**Filters:** Model has filters to help remove grease from the steam emanating from the pans during cooking.



**D:** Product energy rating, measured from A+++ to D / G depending on the product family.



**Lights:** All cooker hoods feature lights to illuminate the cooking area or add to the ambience of the kitchen.