

KSET66VNE2

Product family	Hood
Hood Type	Telescopic Cooker Hoods
Design	Telescopic
Extraction	Ducted out or re-circulation possible
Material	Stainless steel
Type of steel	Brushed
EAN code	8017709256920
Hood width	60 cm



Aesthetics

Aesthetics	Linea	Glass Type	Black
Colour	Black	Serigraphy colour	White
Finishing	Brushed	Logo	Silk screen

Controls

Control setting	Slider
-----------------	--------

Programs / Functions

No. of speeds	3
---------------	---

Technical Features

			
No. of lights	2	No. of filters	2
Light type	LED	Anti-grease filters	Aluminium
Light power	1 W	Vent outlet	150 mm
Free outlet maximum capacity	620 m ³ /h	Minimum distance from GAS hob	650 mm
Motor power	140 W	Minimum distance from ELECTRIC hob	650 mm

	Extraction rate IEC 61591 [m ³ /h]	Noise level IEC 60704-2-13 [dB(A)]
Speed 1	295	52
Speed 2	435	61
Speed 3	580	68

Performance / Energy Label



Annual Efficiency Consumption (AEChood)	78 kWh/year	Airbourne acoustical A-weighted sound Power Emission at minimum speed (SPEmin)	52 dB(A)
Energy efficiency class (EEC)	C	Airborne acoustical A-weighted sound Power Emission at maximum speed (SPEmax)	68 dB(A)
Fluid Dynamic Efficiency (FDE)	14,4	Time increase factor (F)	1,5
Fluid Dynamic Efficiency class (FDEC)	D	Energy Efficiency Index per first cavity	83,5
Lighting Efficiency (LE)	59 lux/W	Measured air flow rate at best efficiency point (Qbep)	322 m ³ /h
Lighting Efficiency Class (LEC)	A	Measured air pressure at best efficiency point (Qbep)	224 Pa
Grease Filtering Efficiency (GFE)	76 %	Measured electric power input at best efficiency point (Wbep)	139 W
Grease Filtering Efficiency Class (GFEC)	C	Normal Power of the light system (WI)	2 W
Air flow at mininum speed (Qmin)	295 m ³ /h	Average illumination of the light on the cooking surface (Emiddle)	130 lux
Maximum extraction rate	580 m ³ /h	Sound power level at highest setting (Lwa)	68 dB(A)

Electrical Connection

Nominal power	142 W	Frequency (Hz)	50-60 Hz
Voltage	220-240 V	Power supply cable length	1500 mm

Also available

Alternative colours available

White, Stainless steel, Silver Glass

Available colours

KSET66VBE2 - KSET66E - KSET66VSE2

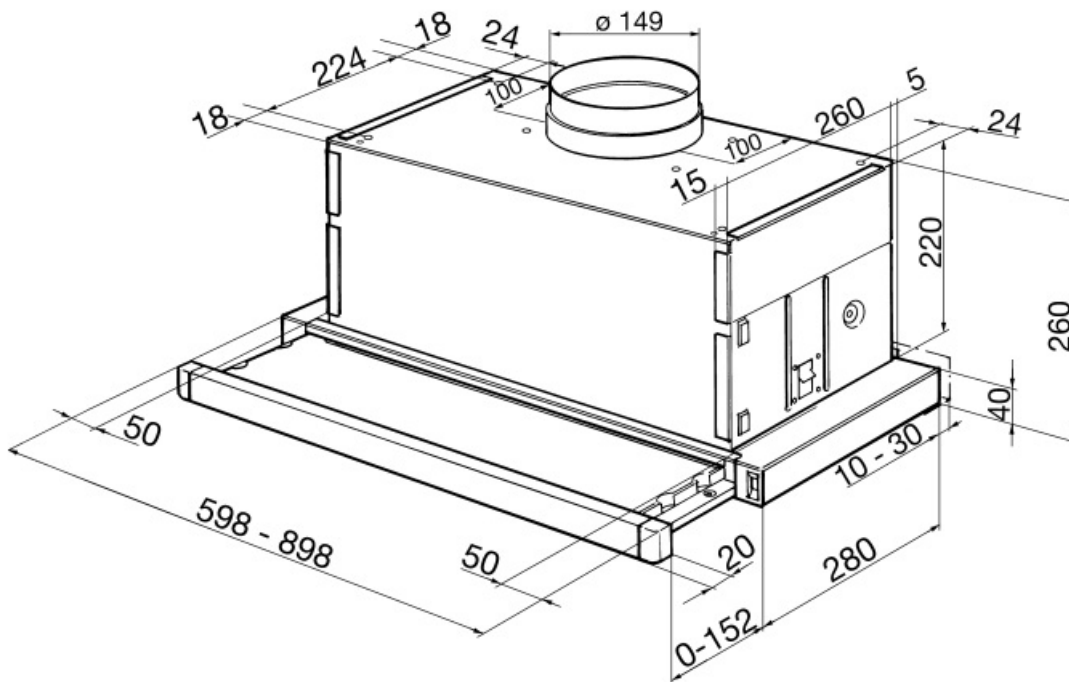

Not included accessories



KITFC152

Charcoal filters Round Kit 2 pieces

Symbols glossary



Filters: Model has filters to help remove grease from the steam emanating from the pans during cooking.



C: Product energy rating



Lights: All cooker hoods feature lights to illuminate the cooking area or add to the ambience of the kitchen.